

Quality joinery since 1956.

WINDOWS | DOORS

# SKAALA<sup>®</sup>

**Keep for  
future use**

Contains important  
information.

WARRANTY CONDITIONS

User, installation and  
maintenance manual

## Contents

Receiving goods.....	3
Product storage.....	3
Installation.....	4
Tracing the products.....	4
Protecting the products with tape.....	5
Windows installation.....	6
Using the windows.....	7
Maintenance – top swing reversible windows.....	9
Maintenance – tilt & turn window and doors.....	10
Hanging – tilt & turn window and doors.....	11
Adjustments – tilt & turn window and doors.....	12
Installation of exterior and balcony doors.....	13
Using the exterior and balcony doors.....	14
Installation of interior doors.....	15
Installation of double doors.....	16
Maintenance of skaala products.....	17
Additional equipment.....	19
Problems and solutions.....	21
Warranty.....	25
Certified quality management.....	26

## Superior quality

Skaala Windows and Doors Ltd is a Finnish company specialized in delivery and service of complete solutions for doors and windows and was established in 1956. Over the years Skaala has grown from being a local carpenter company to becoming one of the most influential, Nordic manufacturers in the business.

In this manual you will find all of the most crucial and commonly needed instructions for installation, use and maintenance of the Skaala products as well as warranty terms and conditions. We highly recommend that you read this manual carefully and that you follow its advice closely. This way we can guarantee that you are able to use your Skaala product with a minimal amount of effort. By following the instructions in this manual you will also ensure the long-term durability and service of the product.

Please preserve the packing list delivered with your products, the order confirmation number and the bill of lading carefully. On basis of the number our customer service is able to help you in all matters concerning Skaala products.

Thank you for choosing  
our Skaala products.

**SKAALA**<sup>®</sup>

## RECEIVING GOODS

Please inspect the condition of the package immediately together with the driver. In case there are signs of transportation damage, describe the nature of the damage clearly in the bill of lading. Please note! The transport company and Skaala are not responsible for any transportation damages which have not been mentioned in the delivery note.

In case the transportation damage is hidden (the kind of damage which does not show on the outside of the package), you must report this in writing to the transportation company within 7 days of receiving the product.

Please make sure that the delivered goods correspond to the order confirmation and that all items mentioned in the covering letter are included. Missing items must be reported in writing within 7 days.

Defective or incorrect delivery and potential transportation damages must be accounted for in the delivery note and reported immediately to Skaala or the distributor.

## PRODUCT STORAGE

The doors and windows must be stored in dry and well-ventilated facilities, protected from soiling and mechanical damage. The products should not be stored outdoors.

In case it is unavoidable to temporarily store the products outdoors, their plastic covering must not be broken. The products must also be covered carefully with a tarpaulin. Rain water pouring down the tarpaulin must not connect with the products.

The covering should still be loose enough to allow any moisture inside the tarpaulin or the plastic covering to be ventilated. If the floor or the storage room is humid or the products are stored on the ground, the packages must be lifted onto supports out of range of humidity (min. height of pallet approx. 20 cm). Once the plastic covering is removed, any loose parts, such as lever handles, should be collected and preserved.

In case the product is defect due to the manufacturer, the manufacturer will repair the defect or deliver a new product or a new part to replace the broken one. The buyer is not allowed to repair any perceived defects themselves on behalf of the manufacturer without first consulting the manufacturer.

**Please note!** Humidity occurring in particularly during the construction of stone houses must be removed from the surface of the products.

**In the storage of fire-resistant windows (compacting window EI30 or EI15/E30) you must also consider the following:**

- the windows can basically be stored following the instructions for ordinary windows above
- the temperature, however, must not rise to more than +50 °C, nor must the inner window sash suffer prolonged exposure to UV radiation (sunlight)
- thermal and UV radiation do not endanger the fire resistance of the glass as such, but prolonged exposure might darken the fire-resistant glass



## INSTALLATION

We recommend that you employ a specialized installation team for installing your doors and windows. Damages caused to the product or the surrounding structures by incorrect installation are not included in the product warranty.

Doors and windows must not be used as supporting structures. When installing, always consider the controllable removal of water from the structure. The windows must always be fastened with screws, e.g. Jamo mounting screws (Würth). The window must never be installed with mere urethane foam.

### **Please note! Do not install defect products!**

To prevent damage to the structures surrounding the products it is important that the frame laths and capping are put in place immediately after installing the products.

## TRACING THE PRODUCTS

Our products are equipped with an information label with the help of which the product can be traced all the way back to the moment of manufacturing. This label makes it easy to order any additional equipment.

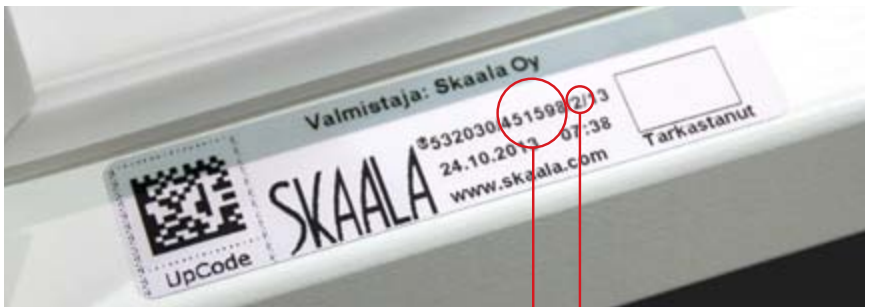

Skaala information label

Row/Product  
Order confirmation number



## PROTECTING THE PRODUCTS WITH TAPE

If it is necessary to protect the products with tape during the construction period, you must make sure that the tape you use is suitable for this purpose. Different plasticizers are used to improve the adherence of the tape and in some tapes this agent may be too strong for painted surfaces.

According to tests the following tapes are best suited for painted surfaces:

- Scotch 2090-2 (3M), masking tape. The best tape for painted surfaces, but if covered with large amounts of plastering the tape might snap when it is pulled off.
- Prof masking tape
- Scotch (3M) construction tape (black, not transparent)
- Tesa 4334, precision masking tape
- Tesa 5258, weather-resistant masking tape

### **Please note! Orange plastering tape must not be used on our products!**

All kinds of tape must be removed as soon as possible once the plastering is finished, at the latest one week later. We also recommend that you tape the door or window frames, thus making it easier to repair any potential damages.

Skaala Windows and Doors Ltd are not responsible for damages caused by disregarding these instructions. If damage arises we recommend that you contact the supplier of the tape.

Damages caused by tape can be repaired by:

- polishing the edge of the damaged area
- touching up the paint twice.



## WINDOWS INSTALLATION

1. Insert stable installation wedges under the window sill and ensure that the sill is level by using a builder's level. A sufficient amount of insulating material must be used around the installation wedges. When installing large windows (more than 1.5 m<sup>2</sup>) you must make sure that the installation wedges remain under the window sill.
2. First attach the side jambs with fastening screws, check the cross-measure of the window construction and that the jambs are straight. To ensure the functionality of the product, the cross-measure must not deviate by more than 1–3 mm.
3. Lift the outer sash in place and fasten the hinge pins.
4. Check the mobility of the outer sashes and the frame turning allowance. If needed adjust the hinges by turning them.
5. Put the inner sash in place and fasten the hinge pins.
6. Make sure that the turning allowance is even all round and that the corner joints are fastened. If necessary adjust the hinges by turning them.
7. If necessary fasten the rest of the frame screws and check the cross-measure of the frame. Do not fasten the screws too tightly. If the screws are too tight the corner joints of the frame might break. Cover the installation holes with screw covers. Please note! Screw covers are not included in the standard delivery.
8. Insulate the sides of the window with either mineral wool or joint insulation. Please note that joint insulation material swells to 2–3 times its size.
9. Measure the damp-proof course (DPC), cut it to the right size and fasten it. If needed, add insulation before attaching the DPC. Please note that the front edge of the DPC must protrude at least 30 mm from the wall construction to prevent water from running down the wall.
10. Seal the gap between the DPC and the wall with elastic substance. Ensure that the inclination of the DPC is at least 1:3, rather 1:2 or steeper.
11. Measure the covering strips, saw them to the right size and fasten them. If needed, add insulation before fastening the covering strips.

### **When installing fire-resistant windows (compartment window EI30 or EI15/E30) you must also consider the following:**

- the compartment window frame must be attached to the wall structure with at least 6x80 mm steel screws (the number and placement of the joints: RT 41-10095)
- the gap between the window frame and the surrounding structure should be carefully insulated with incombustible **stone wool** or **fire-resistant polyurethane foam** (Firebreak 44) which meets the require-

ments of the A2-S1, d0 class, in order to make the mechanical suspension fireproof

- the window opening must not be more than 40 mm larger than the external dimensions of the window frame
- if an opening in the seal is sealed, both the substance used and the sealing strip inserted beneath it must be fire-resistant

## USING THE WINDOWS

The windows are opened by releasing the window locks one at a time and then pulling the sash inwards. When closing the window, please make sure that **all of the window locks are shut**.

**Side-hung window sashes more than 150 cm in width must be supported from below when opened. Please note! Windows with separate window locks (and no lever handle) are not meant for the purpose of ventilation.**

The ventilation windows are opened using only one lever handle (see picture 1). The integrated stay/intermediate shutter of the ventilation window makes it possible to open the inner and outer sash simultaneously. The stay comes with a window restrictor, which keeps the window open in any position you like (see picture 2, A). The restrictor is child proof, but also prevents the ventilation window from moving freely as the draft and the wind load changes. Due to child safety issues the ventilation window is preset at the factory to open maximally 100 mm. Always keep your children's safety in mind when adjusting the restrictor.

The inner and outer sashes can be separated for washing by unlocking the stay by rotating it 90 degrees (see picture 2, B). After washing the windows, please make sure that the stay is locked properly.

On a ventilation hatch only the hatch itself is operating. A solid grille (timber or metal) with anti-insect mesh is installed in the outer sash of the hatch frame.

If needed, the turning allowance of the windows may be adjusted by detaching the sash and rotating the hinge either on the sash or on the frame. Before making any adjustments, however, please make sure that the window frames have been installed levelly (e.g. by checking the cross-measure).

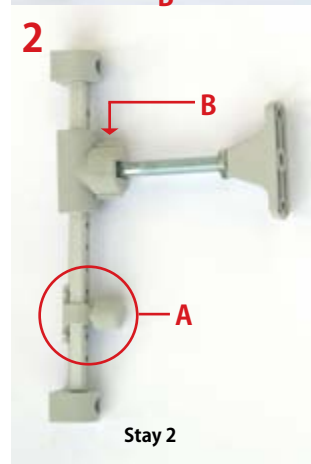
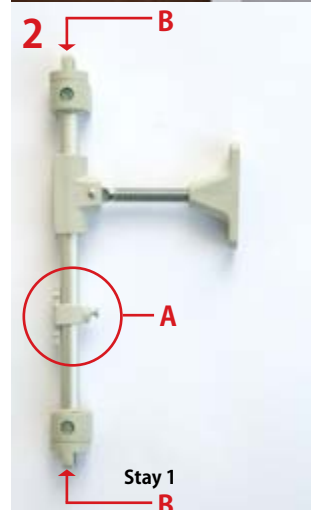

### Retrofit of stay WF881

Used as additional stay and window restrictor in inward opening, side-, top- or bottom-hung ventilation windows and large fixed windows.

- the installation is to be made in such a place that the largest ventilation opening is 100 mm
- use the wood screws delivered with the stay
- drill preliminary holes with a 1.5–2 mm drill for fastening of the screws
- attach the stay shaft (picture 3 A) to the bottom of the inner sash, on the outer surface of the sash
- attach the sliding shaft of the stay (picture 3 B) to the outer surface of the bottom window frame

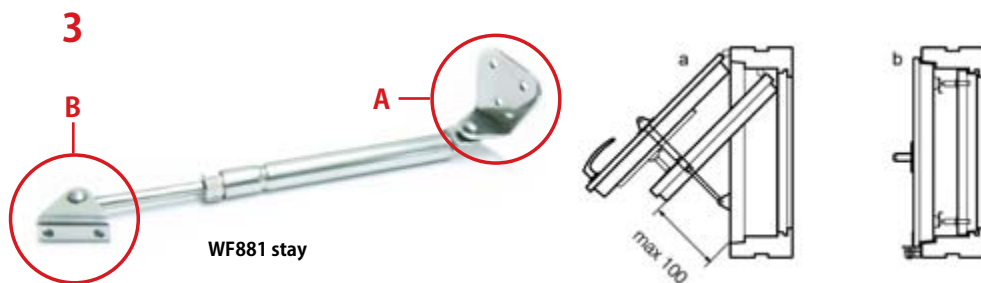

Installed WF881 stay viewed vertically (a) and horizontally (b).

### When using fire-resistant windows (compartment window EI30 or EI15/E30) you must also consider the following:

During usage all window fittings must be closed. No Venetian blinds, fresh air vents or any other accessories requiring traversing the structure mechanically must be attached to the window. The type approval plate on the window must not be removed.

### When opening the fire-resistant window for washing or maintenance, also consider the following:

- do not remove the cotter bolts of the hinges when washing the window
- please use the lever handle manufactured for this purpose for opening the window locks
- a large sash (more than 1 m<sup>2</sup>) must be supported from below
- after washing and performing maintenance, remove the support and **close the window by locking all of the window locks.**

**Please note! A fire-resistant window is only to be opened during installation, maintenance and to be washed. The window must not be used for ventilation.**

## MAINTENANCE – TOP SWING REVERSIBLE WINDOWS

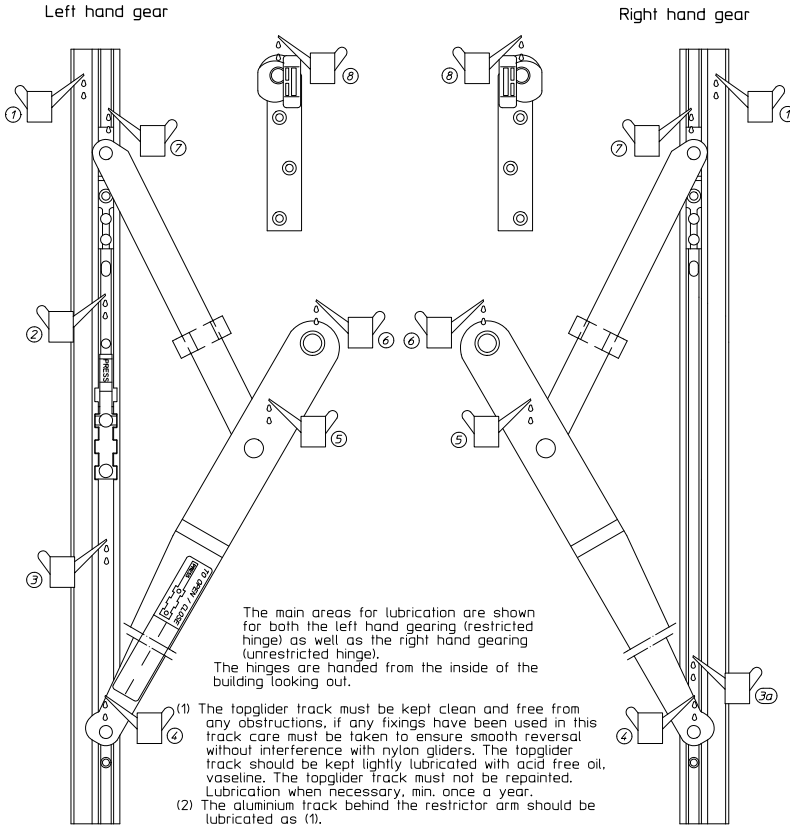

The main areas for lubrication are shown for both the left hand gearing (restricted hinge) as well as the right hand gearing (unrestricted hinge). The hinges are handed from the inside of the building looking out.

- (1) The topglider track must be kept clean and free from any obstructions, if any fixings have been used in this track care must be taken to ensure smooth reversal without interference with nylon gliders. The topglider track should be kept lightly lubricated with acid free oil, vaseline. The topglider track must not be repainted. Lubrication when necessary, min. once a year.
- (2) The aluminium track behind the restrictor arm should be lubricated as (1). The fixing screws should be secured making sure they do not interfere with the smooth movement of the gearing. Lubrication when necessary, min. once a year.
- NB: (3) The steel bar on the left hand restricted arm should be lubricated during fabrication as (1). Lubrication when necessary, min. once a year.
- (3a) Wheel on right hand unrestricted hinge should be lubricated as (1). Lubrication when necessary, min. once a year.
- (4,5,7,8) Rivets to be lubricated as (1). Lubrication when necessary, min. once a year.
- (6) Pivot point is pre lubricated from production. Check it is still intact, if not then lubricate. Lubrication when necessary, min. once a year.

**Note:** Frequency of lubrication must be increased in corrosive areas.

H377691-180

# MAINTENANCE - TILT & TURN WINDOW AND DOORS

## FAVORIT Si-line - Security System Timber

Druckstand: 01.09/Ha/2

22222\_3\_09.01/0

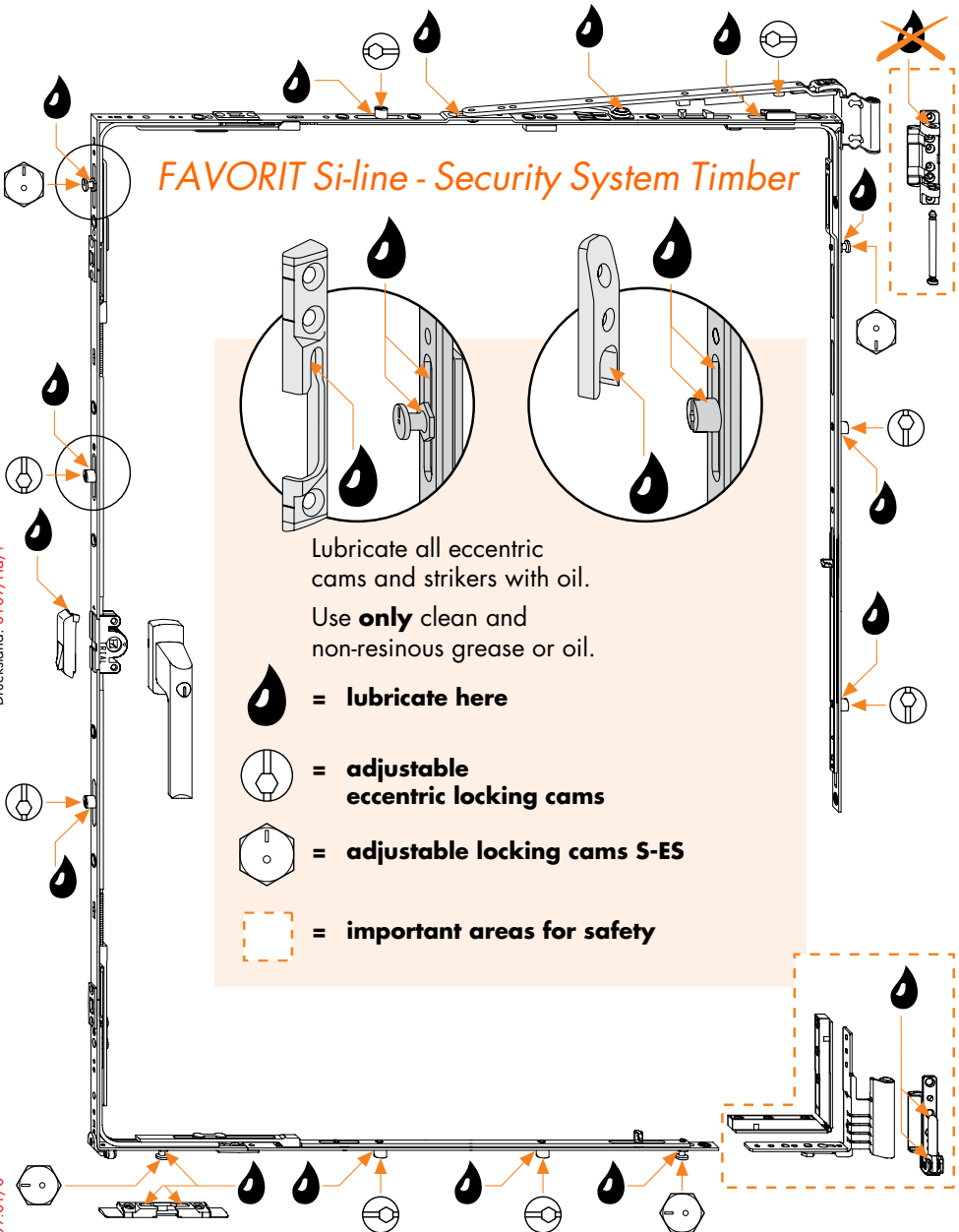

Lubricate all eccentric cams and strikers with oil. Use **only** clean and non-resinous grease or oil.



= lubricate here



= adjustable eccentric locking cams



= adjustable locking cams S-ES



= important areas for safety



**SIENIA®**

## HANGING - TILT & TURN WINDOW AND DOORS

### 1. Hanging sash onto bottom hinge

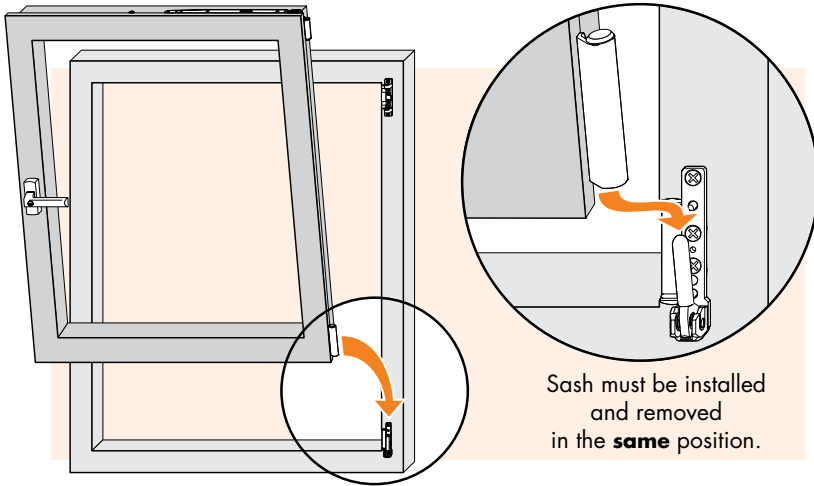

### 2. Connection to top hinge with built-in friction

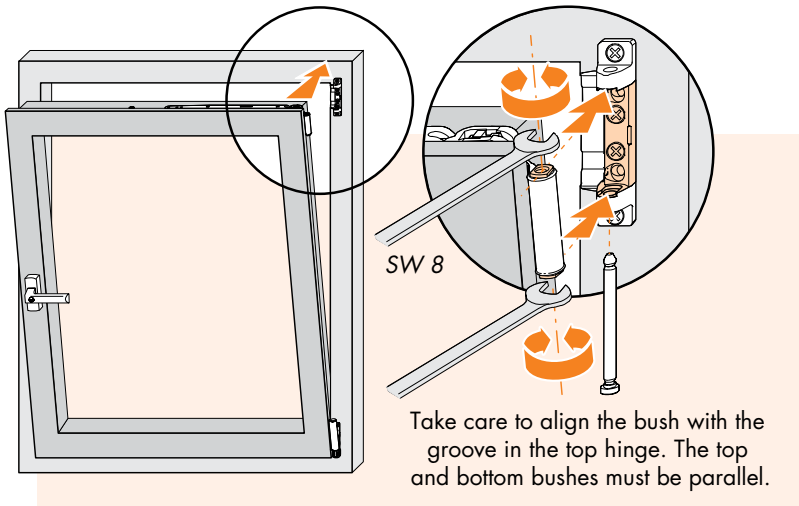

# ADJUSTMENTS - TILT & TURN WINDOW AND DOORS

## Stay

Side to side adjustment

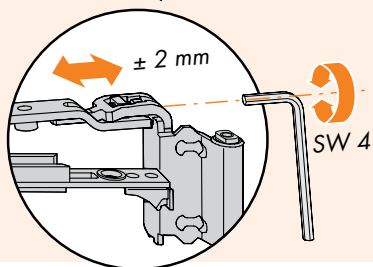

Closing pressure adjustment

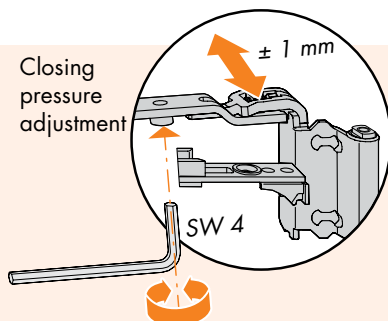

## Eccentric locking cams

Sash closing pressure adjustment

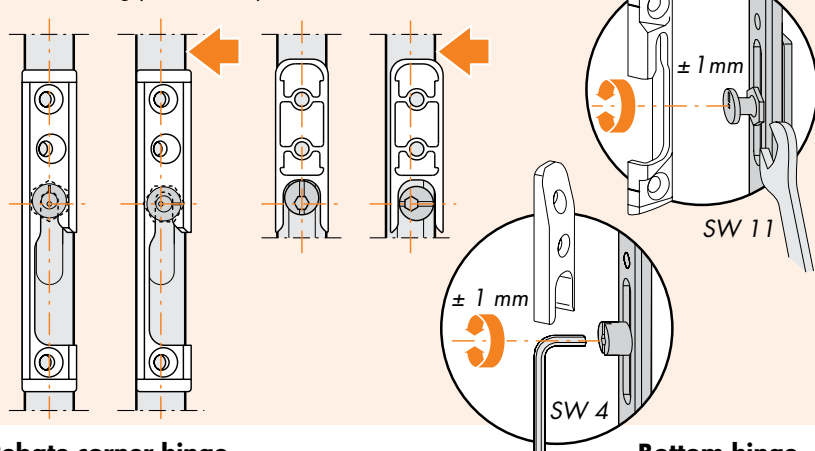

## Rebate corner hinge

Closing pressure adjustment

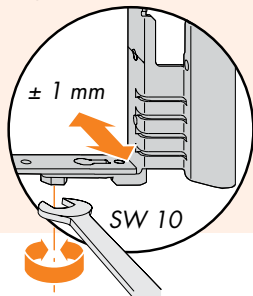

Height adjustment

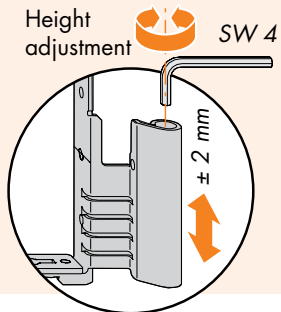

## Bottom hinge

Side to side adjustment

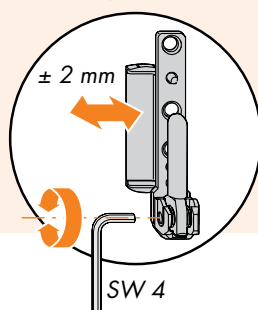

**SIEGENIA®**

## INSTALLATION OF EXTERIOR AND BALCONY DOORS

1. Ensure that the base of the threshold is level and sealable.
2. Insert the frame in place, wedge with double wedges (in order to prevent warping).
3. Check that the frame is level by using a builder's level and taking the cross-measure.
4. Attach the frame on the hinge side by using the screws designed for this purpose.
5. Hang the door leaf on its hinges and make final adjustments to the frame so that the frame and the door leaf are level at every point.
6. Make sure that the turning allowance is even all round and that the corner joints of the frame are fastened. If necessary adjust the hinges.
7. Ensure that the door opens and closes easily.
8. Attach the other sides of the frame. It is a good idea to cover the attaching holes with screw covers. Please note! Screw covers are not included in the standard delivery.
9. Insulate the gap between the frame and the wall with insulation wool or urethane foam. Take care so that the frame does not bulge due to excessive insulation.
10. Measure the covering strips, saw them to the right size and fasten them. If needed, add insulation before fastening the covering strips.
11. The door fittings should be attached during installation. The product warranty does not apply to any damage caused by leaving the fittings unattached (e.g. humidity-induced damage).

**Please note!** To ensure that the door does not get worse for wear prematurely, it should be fastened well and its cross-measure should be precise. This is even more important regarding double doors and doors with one operating sidelight, since any potential deviation in the measure doubles where the door elements meet. The door may be adjusted by +4 mm vertically and +3 mm horizontally.

### Adjusting the door leaf vertically

- remove the head bolt from one of the hinges (see picture 1)
- turn the hex cap screw inside the hinge (see picture 2) clockwise until the door reaches the desired height (one turn lifts the door by 1.25 mm)
- adjust all of the door hinges so that they carry the weight of the door evenly
- finally screw the head bolts of each hinge (see picture 1) in place

Tools needed: hex key AV5





### Adjusting the door leaf horizontally

First, always ensure that the cross-measure of the door is accurate and that the frame is level. Since the door is in frequent use, the attachment of the frame might change due to movement in the structures or as a cause of wear.

### Enlarging the turning allowance between the door and the frame on the hinge side

- loosen the fastening screws of the hinge in the door frame (see picture 3) by a couple of turns
- turn both of the hinge adjustment screws (see picture 4) clockwise as much as necessary (one turn moves the door leaf approx. 2 mm towards the lock side)
- fasten the fastening screws (see picture 3)

Tools needed: hex key AV4 and a suitable screwdriver for the fastening screws

## USING THE EXTERIOR AND BALCONY DOORS

The type of lock chosen affects the usage of the door. If the door is fitted with a LC 100 lock case, please note the following regarding usage.

### Skaala key & handle operated multi-point locks

Handle operated multi-point locks require a door handle on the inside and outside and are locked by pulling the handle up. The significant lever force pulls the door into the seal. The handle then returns to its starting position using spring action and the door can be unlocked simply by pushing the handle down again. A single key turn will block the multi-point lock. It is unlocked again by turning the key once. Key-operated multi-point locks by KfV are locked by a double key turn. Two turns are also required for unlocking.

### Opening the door with a key from outside

- turn the key clockwise until it stops
- turn the key back to its initial position
- remove the key from the lock
- open the door with the lever handle; the door locks once it is shut
- **do not leave the key in the lock**

### Opening the door with the thumbturn from inside

- turn the thumbturn 90 degrees clockwise until it stops
- open the door with the lever handle
- the thumbturn will automatically return to a horizontal position and the door locks once it is shut

### Using the balcony doors – When fitted with FIX896F, lock&FIX-150 Brake

- the stay operates when you turn the lever handle (see picture 5)
- open the door in the desired ventilation position
- turn the lever handle into closed position (downwards)
- the door is locked in place and will not slam shut even in a strong wind
- if the lever handle is in open position (horizontal), the door slides freely

**Please note!** Do not move the door in ventilation position. This might decrease the frictional resistance of the stay prematurely. Wipe the stay with a damp cloth when needed. Oil the sliding part with a few drops of oil at least once a year.

## INSTALLATION OF INTERIOR DOORS

1. Ensure that the base of the threshold is level and sealable.
2. Insert the frame in place, wedge with double wedges (in order to prevent warping).
3. Check that the frame is level by using a builder's level and taking the cross-measure.
4. Attach the frame on the hinge side by using the screws designed for this purpose.
5. Hang the door leaf on its hinges and make final adjustments to the frame so that the frame and the door leaf are level at every point.
6. Make sure that the turning allowance is even all round and that the corner joints of the frame are fastened. If necessary adjust the hinges.
7. Ensure that the door opens and closes easily.
8. Attach the other sides of the frame. It is a good idea to cover the attaching holes with screw covers.
9. Insulate the gap between the frame and the wall with insulation wool or urethane foam. Take care so that the frame does not bulge due to excessive insulation.
10. Measure the covering strips, saw them to the right size and fasten them. If needed, add insulation before fastening the covering strips.
11. The door fittings should be attached during installation. The product warranty does not apply to any damage caused by leaving the fittings unattached (e.g. humidity-induced damage).

**Please note!** To ensure that the door does not get worse for wear prematurely, it should be fastened well and its cross-measure should be precise. This is even more important regarding double doors and doors with one operating sidelight, since any potential deviation in the measure doubles where the door elements meet.

### Raising the door leaf (vertical adjustment $\pm 3.5$ mm)

- loosen both the lower screws on the hinges (1) two to three turns
- turn the upper screw on one of the hinges (2) until the door reaches the desired height (one turn lifts the door by 1.25 mm)
- adjust the upper screw on the other hinge (1) so that the weight of the door is carried evenly
- finally fasten the lower screws on the hinges (1) lightly

Tools needed: screwdriver, blade width 5...7 mm

### Adjusting the door leaf horizontally (horizontal adjustment +1.5/-2.5 mm)

- the adjustment is best made when the door is opened at approx. 90 degrees
- turn the hex cap screw of the hinge (3) two to three turns clockwise so that the adjuster sleeve (4) can be rotated freely
- the door leaf can be moved either towards the lock side or the hinge side
- if you wish to move the door towards the frame on the hinge side, turn the adjuster sleeve (4) counter-clockwise as many turns as needed (one turn moves the door 1.25 mm)
- if you wish to move the door towards the lock side, turn the adjuster sleeve (4) clockwise
- finally lock the adjuster sleeve (4) by fastening the hex cap screw (3) as tightly as possible by turning it counter-clockwise



Tools needed: hex key AV3, screwdriver with blade width 8...10 mm

## INSTALLATION OF DOUBLE DOORS

1. Ensure that the base of the threshold is level and sealable.
2. Put the lower edge of the frame in place on floor level. All floor surfacing, such as parquet, should be in place before you fasten the frame. The threshold makes it easier to install the frame. Install the frame, wedge with double wedges (in order to prevent warping). It is crucial that you insert the wedges.
3. Check that the frame is level by using a builder's level and taking the cross-measure.
4. Attach the frame on the hinge side by using the screws designed for this purpose.
5. Hang the door leaf on its hinges and make final adjustments to the frame so that the frame and the door leaf are level at every point.
6. Make sure that the turning allowance is even all round and that the corner joints of the frame are fastened. If necessary adjust the hinges.
7. Ensure that the door opens and closes easily.
8. Attach the other sides of the frame. It is a good idea to cover the attaching holes with screw covers.
9. Insulate the gap between the frame and the wall with insulation wool or urethane foam. Take care so that the frame does not bulge due to excessive insulation.
10. Measure the covering strips, saw them to the right size and fasten them. If needed, add insulation before fastening the covering strips.
11. The door fittings should be attached during installation. The product warranty does not apply to any damage caused by leaving the fittings unattached (e.g. humidity-induced damage).

**Please note!** To ensure that the door does not get worse for wear prematurely, it should be fastened well and its cross-measure should be precise. This is even more important regarding double doors and doors with one operating sidelight, since any potential deviation in the measure doubles where the door elements meet.



Tools needed: hex key AV3, screwdriver with blade width 8...10 mm

**Please note!** Always follow the separate installation instructions delivered with the door.

### Raising the door leaf (vertical adjustment $\pm 3.5$ mm)

- the adjustment can be made without lifting the door off its hinges
- open the door approx. 90 degrees and lift it approx. 10 mm, so that the hinge pin in the rolling of the pin leaf is no longer level with the adjustment slot (1)
- insert the needed number of hardened adjusting plates (2) into the adjustment slot (1); one adjusting plate lifts the door by 1 mm
- insert the same number of adjusting plates into each hinge

## MAINTENANCE OF SKAALA PRODUCTS

The Skaala products have been designed to be low maintenance. The climate and regional as well as structural elements affect the need for maintenance of the doors and windows.

### **The need for maintenance is affected by:**

- precipitation
- the height and shape of the house as well as the eave length and inclination
- cardinal directions
- location by the sea/a lake, wind conditions
- the ventilation in the house
- the humidity of the structures
- means of installation and the condition and functionality of the surrounding wall
- the colour of the surfaces

The most common cause of damage to timber is humidity. It is important that the timber is allowed to dry before repairing damages or repainting. When painting the humidity of the timber must exceed 20%. While painting and letting the paint dry the temperature of the air, the surface and the paint must be above +5 °C and the relative humidity below 80%.

The recommendations for service intervals in this manual are guidelines. The actual need for maintenance becomes evident by checking the condition of the doors and windows often enough, at least once a year. The service interval for products in dark or special colours may be shorter than for those in standard white.

To ensure uninterrupted functionality you had better check and if necessary perform maintenance on the seals and fittings of the products annually. Painted surfaces and seals should be washed when washing the windows at least once a year. If a seal comes undone or suffers damaged, it should be replaced by a corresponding seal. When washing the windows the fittings (hinges and locks) should be oiled. Any broken parts should be replaced by new ones. Broken glass must likewise be replaced. We recommend that you contact a business within the trade to have the glass replaced.

The doors must also be washed regularly (at least twice a year), in order to prevent fungi from growing on the surface.

Painted surfaces are washed by wiping them with a damp cloth. You should add alkaline detergent, e.g. washing-up liquid, to the water. Avoid using strong solutions or superfluous detergent, since they may damage the painted surfaces. When using anti-fungus washing liquids please check with the manufacturer of the liquid whether the surface needs to be repainted after use. Certain anti-fungus liquids might remove the fungicide agent.

The surface treatment on the exterior of timber and panel constructions should be inspected annually. If there are any dents or cracks, these should be mended immediately.

### **Maintenance of a finishing painted surface**

- Remove all peeling paint mechanically; all other surfaces should be clean of dirt and dust. Hardened dirt can be removed by polishing with abrasive paper.
- Remove any potentially porous wood e.g. by polishing.
- Any potentially fungi infested parts should be washed with anti-fungus detergent, carefully rinsed with water and allowed to dry.
- Bare wooden surfaces should be treated with a transparent timber preservation agent.
- Cover any potential cracks with putty (1 or 2 component putty).
- Paint the surfaces requiring paint in the colour you like. The exterior surfaces should be painted with elastic acrylic paint suited for outdoor use. The standard colour white is NCS-S 0502 Y and the glazing varnish 20.

In case there are only fine hair cracks in the painted surface, a light polish (removing the glazing) and a surface paint with a suitable indoor/outdoor paint is sufficient repair.

### **Maintenance of a glazed (pine) surface**

- Remove all peeling glazing mechanically; all other surfaces should be clean of dirt and dust. Hardened dirt can be removed by polishing with abrasive paper.
- Remove any potentially porous wood e.g. by polishing.
- Any potentially fungi infested parts should be washed with anti-fungus detergent, carefully rinsed with water and allowed to dry.
- Cover any potential cracks in the surface treatment paint with the best suited wood putty possible. Please note! When using putty, keep in mind that after applying a coloured glazing treatment to the mended places, the colour might differ slightly from that of the rest of the surface.
- The surface is to be treated with a transparent timber preservation agent of the original glazing colour and allowed to dry for approx. 24 hours.
- After the glazing treatment you can varnish the surfaces with a UV radiation resistant varnish in a colour of your own choice and meant for outdoor use.

Exterior surfaces of aluminium are maintenance free. However, it is necessary to wash them regularly and thoroughly at least once a year. If necessary the aluminium parts can be painted with alkyd- or urethane-based paint suited for this purpose. The water draining holes in the lower lathes of the frames must be cleaned at least once a year.

### **Maintenance of veneered doors is performed as follows:**

- If needed polish the surface lightly with abrasive paper, grain 180–240.
- Remove the polishing dust carefully.
- Wash the surface with a neutral detergent and allow it to dry for at least 48 hours.
- Oil the door with wood oil suitable for this treatment.

Doors with a wood veneered surface are treated with wood oil at the factory. We recommend that you treat the door again as soon as it has been installed. A veneered door usually needs to be oiled regularly at least once a year. In demanding conditions you had better oil the door twice a year.



**When performing maintenance on fire-resistant windows (comparting window EI30 or EI15/E30) you must also consider the following:**

In case the dilating fire-resistant seals surrounding the sash or the insulating glass are damaged, they must be replaced by corresponding products. Should this happen it is best to contact the manufacturer. The seals must not be removed when washing or repainting the windows.

When opening a large (more than 1 m<sup>2</sup>) fire-resistant window to be washed, it is vital that you support the sash. The need to support a fire-resistant window arises for smaller sizes than for ordinary windows since the glass in the fire-resistant windows is considerably heavier.

## ADDITIONAL EQUIPMENT

### Removing clip-on bars e.g. during wash

Use a screwdriver of an appropriate size. When opening the clip-on bars, turn the screw 180 degrees counter-clockwise, when fastening 180 degrees clockwise.

### Removing the anti-insect mesh

Open the window and unlock the intermediate stay (see opening the intermediate stay on page 7). Press the plastic clips keeping the anti-insect mesh in place to the sides, so that the sash moves inwards. Remove the sash and lock the intermediate stay. Installation is done in reverse order.

**The anti-insect sashes and bars** are made from weather-resistant material. We strongly recommend that you remove the anti-insect mesh from the window during winter in order to avoid any damages caused by birds or frozen water. The anti-insect sashes should be washed lightly before putting them in winter storage.

Please note that the Skaala warranty does not include indirect damages or external third-party damages (caused by water/ice, birds etc.).

**The fresh air vents** must not be blocked since they ensure that the ventilation in the building works. It is recommended that you clean the filters in the fresh air vents at least twice a year. The vent and the filter unit are removed by unfastening the screws fixing them to the frame. Inside the filter cover there is a cellular plastic filter, which can be cleaned with a soap solution. Vacuum the air duct of the sound absorber, taking care not to damage the surface coating of the soundproof material. Install the parts in place.



**Fresh air vent**

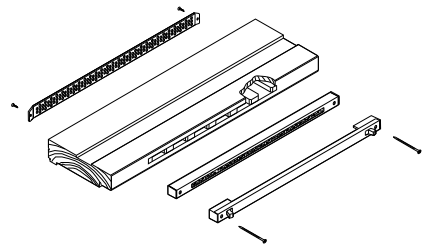



### **Biobe ThermoPlus supply air windows** **Adjusting the summer, closed and winter positions**

The summer, closed and winter position is adjusted with the lever at the end of the vent. The summer position is to the left, closed position in the middle and winter position to the right.



### **Changing the vent filter**

The vent is equipped with honeycomb shaped Biobe allergy filters. We recommend that you change the filter twice a year.

The vent is removed by unfastening the screws attaching it to the frame. Gently push the adjusting lever of the vent, so that the adjusting rail behind the vent comes loose. Remove the old filter from the notched groove of the vent, put the new allergy filter in its place and put the adjusting rail back into place.

The sound absorber is not to be removed during cleaning. The air ducts of the sound absorber can be vacuumed. Then the vent is put back in place so that the summer, closed and winter position adjuster is to the left.



### **Changing the interspace filter**

Open the window sash and remove the old filter from the moulded opening in the upper frame of the outer glass. At the end of the filter and the moulded opening there is an opening the size of your finger to help you remove the filter. Put the new Biobe allergy filter into the moulded opening by pressing it gently. Make sure that the filter is level with the surface of the upper frame.

The filter material is non-washable. We recommend that you wipe other plastic and aluminium surfaces with a cloth dampened with a mild detergent. The use of solvents is forbidden.



### **Venetian blinds**

The Venetian blinds installed between the windows do not require any special attention or maintenance. It is sufficient that you vacuum them or wipe them with a damp cloth without detergent. The turning mechanism of non-integrated blinds needs to be greased with 100% silicone every two years.



# **WARNING!**

- Young children can be strangled by loops in pull cords, chains, tapes and inner cords that operate the product.

- To avoid strangulation and entanglement, keep cords out of the reach of young children.

Cords may become wrapped around a child's neck.

- Move beds, cots and furniture away from window covering cords.

- Do not tie cords together. Make sure cords do not twist and create a loop



## PROBLEMS AND SOLUTIONS

### **There are air bubbles or scratches in the window glass**

Traces which have arisen during the manufacturing process of the sheet glass may occur. The sheet glass used in windows is not required to be optically flawless; small traces or “bubbles” are approved in the quality specification of the window glass.

There are straightforward instructions for checking deviations in the glass e.g. on the RT card (RT38-10901 p. 5).

### **There are traces of glue or other hard to remove stains on the window glass**

The labels used during the manufacturing process might have left traces of glue on the glass. It is difficult to remove these traces with ordinary detergents. You should remove most of the traces carefully with a glass scraper. Use xylene to remove the rest. You can buy xylene at paint shops etc. Wiping with a cloth dampened with xylene also removes most other hard to remove stains without damaging the glass. Avoid wiping painted wood and aluminium surfaces with xylene. Levelling compounds/concrete which has stained the glass during construction work should be removed immediately. When cleaning the glass, always use plenty of water, a mild alkaline detergent or dissolve the stains with xylene. Do not scrape or rub or try to remove the stains dry.

**Please note! Also see: Observe when cleaning and maintaining glass with special coating.**

### **How to treat self-cleaning Activ glass**

Self-cleaning glass is ordinary glass with a bifocal special coating on the exterior surface. Sunlight dissolves the organic dirt adhering to the glass surface and rainwater washes it away. In certain angles the glass reflects slightly more than ordinary glass and it has a vaguely bluish colour. In every other aspect it is the same as ordinary glass. The coating is secured firmly to the glass and is only damaged if the glass itself suffers damage from e.g. sharp objects, abrasive detergents or steel wool. Like all of our products, you can wash the self-cleaning glass with a mild, alkaline detergent. If the windows do not become clean, this is usually due to lack of sunlight or rainwater.

### **Cleaning Skaala FrostFree windows**

All the glass surfaces of the Skaala FrostFree windows are cleaned like any other glass surface, by using plenty of water and ordinary neutral (or mildly alkaline) detergents or other commercial window washing agents.

In case the windows do not become clean after a normal cleaning, oils or potential organic stains can be removed with acetone or xylene. After using these solvents the glass must be cleaned with water once more.

### **Observe when cleaning and maintaining glass with special coating**

The following applies to self-cleaning Activ glass, K glass (selective) and FrostFree glass.

- Avoid using abrasive cleaning equipment (such as scrapers and steel wool). Mechanical abrasion of glass can cause irreparable damage to the surface. The warranty does not include traces or damages caused by such implements or methods.
- Mechanical abrasion may remove the coating in places
- Avoid all contact between the glass and metal implements
- Avoid the use of all chemicals that might damage the coating permanently
- The use of strong acidic or alkaline substances is forbidden
- Do not clean the windows while they are exposed to direct solar radiation

### **The windows make snapping or cracking noises**

When temperatures vary, the external aluminium parts and the joining materials of the windows warm unequally. Snaps and light cracking noises are due to the different thermal expansion qualities of the different materials. This phenomenon mainly occurs in spring, when temperatures vary greatly at different times of the day. Thermal expansion does not damage the window constructions. The construction design of Skaala products takes the thermal expansion of different materials into account and thus the materials can “move around” freely.

### **Condensation on the window (moisture on the inner surface of the outer sash)**

The condensation is most likely caused by the fact that the warm air in the room is allowed to flow into the interspace and/or that the interspace is not ventilated properly. Follow these instructions:

- Make sure that all locks in the inner and outer sashes are closed.
- Check that the ventilation in the house is sufficient (underpressurized). Do not touch the exhaust air vents once you have checked the ventilation as this will change the planned balance in the ventilation (the underpressure). You can easily check the planned balance with a simple test. Open the ventilation window ajar (approx. 2–3 cm), and hold the flame of a lighter up to the inside of the open ventilation window. If the flame bends outward, the room is overpressurized. Then the warm, moist inside air flows e.g. through the gaps of the fittings or the Venetian blinds into the interspace. In this case, the ventilation should be reset.
- Check the insulation and seals of the inner sashes. You can check that the insulation is working properly with a paper test. Place a few centimetres wide strip of paper between the insulation and shut the window. By drawing the paper from the closed sash you can check that the insulation is sufficient. You should be able to remove the paper, but still feel the resistance of the insulation. Adjust the sash if needed.
- Check the insulation and the ventilation holes in the seals of the outer sashes. Make sure that air is allowed to circulate in the interspace.
- Make sure that the water holes in the aluminium profile in the window sill are not blocked.

**Condensation on the window (moisture on the inner surface of the window)**

The condensation is most likely caused by the fact that the humidity in the room is high and that the glass surface is not ventilated properly. Follow these instructions:

- Make sure that the room is ventilated sufficiently. If there is a fresh air vent in the room/window, check that it is open.
- A suitable relative indoor humidity is 35–55%.
- Make sure that the indoor temperature is normal (20–22 °C).
- Make sure that the curtains, plants and other objects are not preventing the ventilation by the window.

Under certain circumstances, moisture is always concentrated to the (in particularly lower) edges of a fixed window. This is due to the thermal bridges formed from the spacer bars of the insulation glass, which cools down the edge areas of the glass considerably. This phenomenon also occurs when the thermal insulation of the glass itself is better than average. In winter when outside temperatures are very low, this condensation can freeze along the edges of the glass.

In particularly in stone houses, indoor humidity is higher than usual during the first few heating seasons due to the moisture issuing from the constructions. Whenever there is condensation on a fixed window, it is most important to make sure of the conditions mentioned above, i.e. ventilation, sufficiently low indoor humidity and the ventilation of the inner window surface.

**Condensation on the window (moisture on the outer surface of the window)**

At certain times of year, when the humidity is high, there may also be condensation on the exterior of the outmost glass of the windows. The condensation is caused either by the low temperature inside the building or by the efficient thermal insulation of the window. The heat radiating from inside is insufficient and fails to keep the glass dry. Condensation is formed on the exterior of the outer glass when the indoor temperature (and condensation point) outside rises more rapidly than the temperature of the exterior of the outer glass.

Condensation on the exterior of the outer glass usually forms during the night and before dawn, mostly in spring and autumn. The phenomenon is also known to occur during particularly cold spells in winter. In temperatures below zero, the humidity on the exterior surface freezes.

The condensation will disappear either when the air gets warmer (the heat dries the external surface of the glass) or colder (the condensation point becomes lower than the surface temperature of the glass, and thus the humidity evaporates). Condensation does not damage the window. Temporary condensation on the exterior surface is a quality of the thermally well-insulated window.

### **Condensation on the window (moisture in the interspace of insulation glass elements)**

Should humidity concentrate in the interspace of insulation glass elements, the insulation of the insulation glass element is faulty. If this occurs during the 10 year insulation warranty period, we will deliver a new glass element.

### **There are insects or dust in the window's interspace**

The basis for the functionality of double sash windows is that the interspace between the inner and the outer sash is ventilated. This is arranged for by ensuring that the seals have ventilation gaps which allow the air to circulate. There are also water holes in the aluminium profile in the window sill. The holes have two functions: They regulate and lead away the rainwater falling on the profile and enable the ventilation of the interspace. The size of the water holes is measured exactly to make sure that the water is removed. If the water holes or the ventilation gaps are blocked, this might damage the product or the structures surrounding it.

The amount of potential dust and insects in the interspace depends on the location of the residence and the cardinal direction. In certain conditions fine snow might enter the interspace. This does not mean the product is faulty, but is due to an interaction between its qualities and the environment.

### **The fittings are coming loose (applies to both windows and doors)**

That the fittings come loose is a normal consequence of hard wear. However, you can prevent this by using e.g. screw couplings available at hardware stores and car supply shops.

### **The exterior door will not open properly**

See Adjusting the door leaf on page 9.

### **The balcony door will not open properly**

Check that you are using it correctly, i.e. the lever handle must be completely open (90 degrees). See Using the doors – Using the balcony doors on page 10.

### **The door will not lock**

Make sure that the latch enters the counterpart in the right spot. If it does not, check the door adjustments on page 9. If it does, please contact the nearest lock store.

### **Dark stains appear on the surface of the door**

You should perform maintenance on the door regularly and cleaning the products is a significant part of the basic maintenance of the products. Dirt may serve as a substratum for mould fungi. Without regular cleaning, the fungi may damage the painted surface. See the maintenance guidelines for the products on pages 13–15.

## WARRANTY

Skaala Windows and Doors Ltd grants a 2 year product warranty for products manufactured by the company. The warranty applies to the constructions of the doors and windows, the materials and additional equipment listed in the order confirmation. Any modifications made to the construction of the products without Skaala's approval in writing are forbidden and make the warranty invalid.

**The warranty period begins when the product is delivered to the customer.**

If the product is replaced by a new part the warranty contains:

- A. delivery of the new part in a product purchase
- B. delivery and installation of the new part in an installation agreement

### **Warranty of the windows**

Skaala grants a 2 year warranty for the construction of the windows. The warranty is valid only if the window has been installed and maintained according to the instructions, and if the window has not been damaged by water or the sun.

**Please note!** At certain times of year, when the humidity is high, there may be condensation on the exterior of the outmost window glass. The condensation is caused either by the low temperature inside the building or by the efficient thermal insulation of the window. The heat radiating from inside is insufficient and fails to keep the glass dry. Condensation on the exterior of the outer glass usually forms during the night and before dawn. The condensation will disappear when the air gets warmer and will not damage the window. Temporary condensation is a quality of the thermally well-insulated window. **The Skaala FrostFree window stays clear of condensation in all conditions.**

### **Warranty of painted exterior and balcony doors**

Skaala grants a 10 year warranty for that its doors resist warping and a 2 year warranty for the construction of doors manufactured by the company, which have been installed correctly according to the instructions. The door does not warp permanently more than 5 mm. The warranty is valid only if the door has been installed and maintained according to the instructions, and if the door has not been damaged by water or the sun.

### **Warranty of pine and teak veneered exterior and balcony doors**

Skaala grants a 10 year warranty for that its exterior doors resist warping and a 2 year warranty for the construction of doors manufactured by the company, which have been installed correctly according to the instructions. The door does not warp permanently more than 5 mm. The warranty is valid only if the door has been installed and maintained according to the instructions, and if the door has not been damaged by water or the sun. The construction warranty does not apply to cracks in the surface or variations in colour of a pine or teak veneered door that has been exposed to direct sunlight and rainwater.

### **Warranty of insulation glass elements**

A 5 year insulation warranty is granted for the insulation glass elements in all Skaala products. **Please note!** The warranty of insulation glass elements concerning thermal stress becomes invalid if dark blinds or other dark blackout implements are used with the glass elements. Using such equipment in the immediate vicinity of the insulation glass elements increases the risk of thermal shock due to a steeply rising temperature. A thermal shock can break the glass element.

### **Installation warranty**

The installation warranty for doors and windows installed by Skaala Ikkuna- ja Ovipalvelu Oy is valid 2 years from the date when the work is submitted to the customer, provided that Skaala's instructions for receiving, storing, treating and performing maintenance on the products have been observed.

## CERTIFIED QUALITY MANAGEMENT

Skaala is the only wood industry company in Finland certified to all of the following quality management systems:

- ISO 9001      Quality management system
- ISO 14001    Environmental management system
- OHSAS 18001 Occupational health and safety management system

The quality management systems have been audited and issued by Det Norske Veritas (DNV).





skaala.com



# SKAALA®

Skaala Windows and Doors Ltd  
Yrittäjätie 25  
P.O. Box 17  
FI-62375 YLIHÄRMÄ  
Finland  
Tel. +358 (0)10 8354 700

